

Full Automatic CNC Small Hole Drill EDM

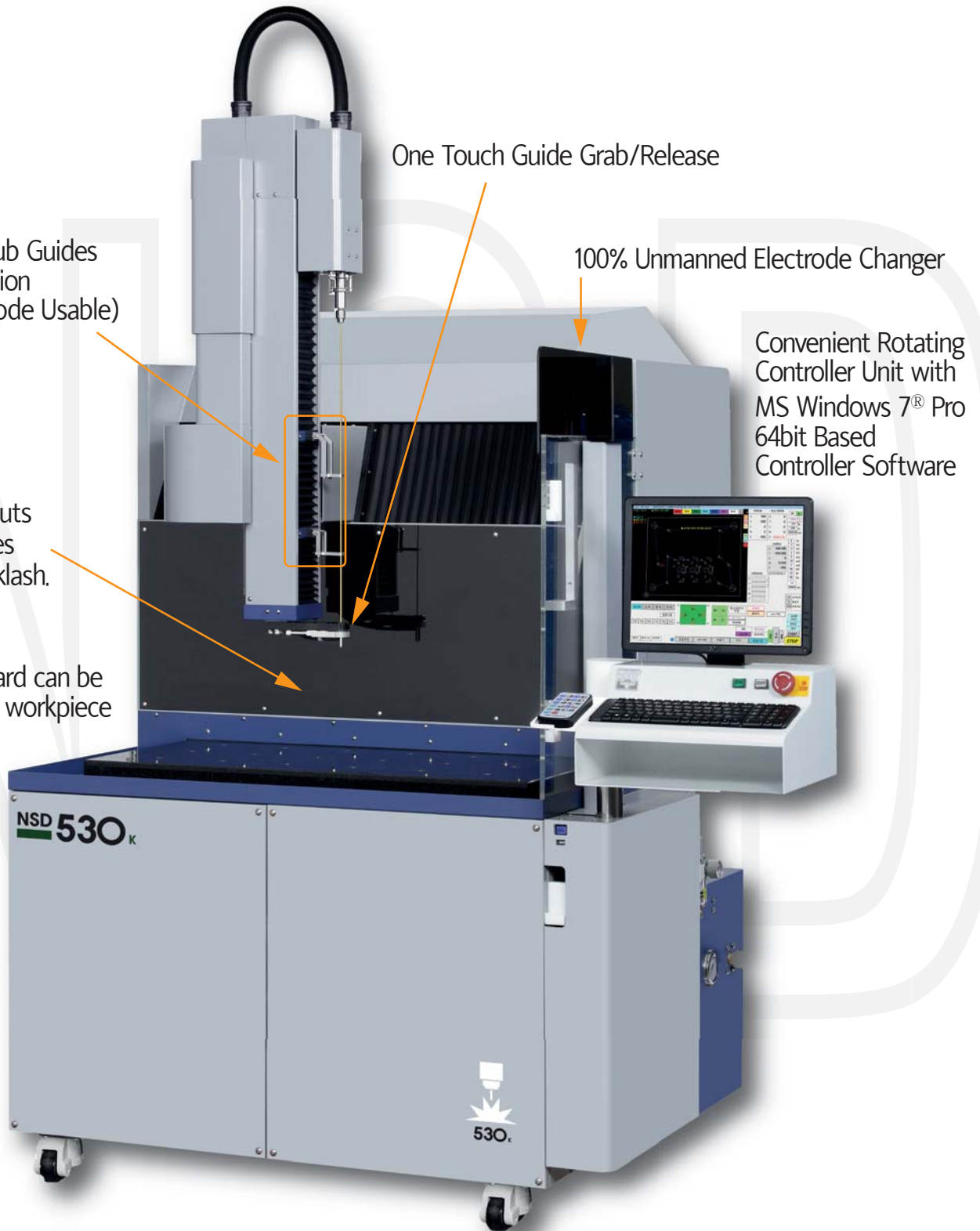

3 stage fine discharge control for stable drilling

Features and Specifications

- No Unfinished hole (Auto Penetration System)
- Advanced Check/Compensation for Electrode Wear
- Auto Thickness Verifying System
 - No need to wait until breaking through at the first hole.
- Carbide inserted in the Guide hole for the better durability and accuracy
- Pitch Compensation System not just for X, Y, but also W-X, W-Y.
- Load CAD DXF file directly
- Automatic Edge Finding System
- Max Size of Workpiece: 500 x 300 x 360mm (W x D x H)
- Small Hole Drilling (0.1 ~ 3.0mm)

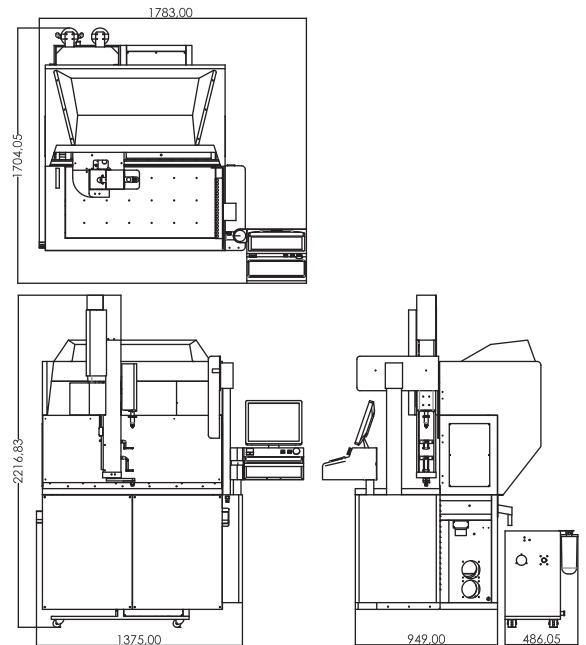

Table Size(X x Y)	Travel Distance(X x Y x Z x W)	Dimensions(W x D x H)
940 x 450mm (37 x 17.7in)	550 x 300 x 640 x 360mm (21.7 x 11.8 x 25.2 x 14.2in)	1790 x 1710 x 2240mm (Max 2600mm) 70.5 x 67.3 x 88.2in (Max 102.4in)

Machine Weight	Max Weight of Workpiece	Water Tank Capacity
1100Kg / 2423lb	300Kg / 661lb	70Liter / 18gal*

* The water tank can be replaced with an optional Larger Water Tank(130Liter/33.4gal).

ATC/AGC holes

1 row(w/o AGC)	1 row(with AGC)	2 row(w/o AGC)	2 row(with AGC)	AGC holes
14	10	28	20	4

* Rated Voltage: 3phase 220/380/400V, 50/60Hz (Select when you order)

* Rated Power Capacity: 5KVA * Max Allowable Current: 30A * Required Air Pressure: 5Kgf/Cm2

Options

- Auto Guide Changer (4 holes)
- 130Liter Large Water Tank
- Large Diameter Drill Pack
(Guide Plate/Collet Chuck for up to 6.0mm)
- 60A Internal Power Booster
- 100A External Super Booster
- Oil Machine (Use EDM Oil as dielectric)
- Submerge Reservoir for Oil
- EDM Tapping (Make Taps on Heat-Treated Material)
- NSD 1/2 Axes Indexer
- Customized model Available



100A Power Booster



NSD Indexer

Head Office & Engineering Lab

#1 La-209 Sihwa Complex, 73, Gongdan 1-daero 28beon-gil,
Siheung-si, Gyeonggi-do KOREA 429-848
tel: +82-31-319-8682 / fax: +82-31-319-8683 / mail: nsd@koreansd.com

